

atrato™

Ultrasonic Flowmeter Range

INSTRUCTION MANUAL



breakthrough flowmeter technology

CONTENTS

1	General	PAGE 4
2	Installation	PAGE 5
3	Electrical	PAGE 6
4	Setup	PAGE 7



The Atrato is a new generation through bore time of flight ultrasonic flowmeters that uses breakthrough technology to offer a wide ranging accurate meter. It is ideal for many process control, instrumentation and laboratory applications. The user must make sure that the flowmeter selected is suitable for the application and that the chemical compatibility, temperature and pressure requirements are within the Atrato's operating range. Please check the model number before proceeding. All meters can be programmed and monitored via the USB connection.

First 3 digits Flow range	Fourth digit Seal mat'l	Fifth digit End fittings	Sixth digit Wetted mat'ls	Seventh digit Electronics
710 = 5-500ml/Min				
740 = 0.05 – 5 L/Min				
760 = 0.2 – 20 L/Min				
	V = Viton			
	N = Nitrile			
	E = EPDM			
	S + Silicon			
		0 = 3/8" John Guest		
		1 = _" BSP		
			0=PEEK/316 SS	
			1=PEEK/Glass	
				Q = Std pulse
				A = Analogue
				D = LED display

For example

760 – V 1 0 – QAD

This is a 20 L/Min flowmeter with Viton seals, half inch BSP fittings and a 316 stainless steel flow tube with PEEK end fittings, fitted with a local digital display and an analogue output.

2

Installation

Locate the flowmeter in a sheltered position away from falling water. Ideally flexible tubes should be used to plumb the flowmeter in as care must be taken to ensure that the end fittings on the meter are not stressed during use. Ideally the meter should be installed with straight lengths of tube either side, 10 pipe diameters upstream and 5 downstream. Install the device well away from valves, regulators bends and other components that would cause excessive turbulence on the fluid entering or leaving the meter. If necessary use spacer blocks and mounting clips to raise the pipe work centre line 58mm above the surface. It is good practice to use upstream and downstream isolating full bore ball valves to facilitate easy meter installation or removal. If push-in 3/8" John Guest fittings are used clip the pipes to the mounting surface 300mm upstream and 150 downstream.

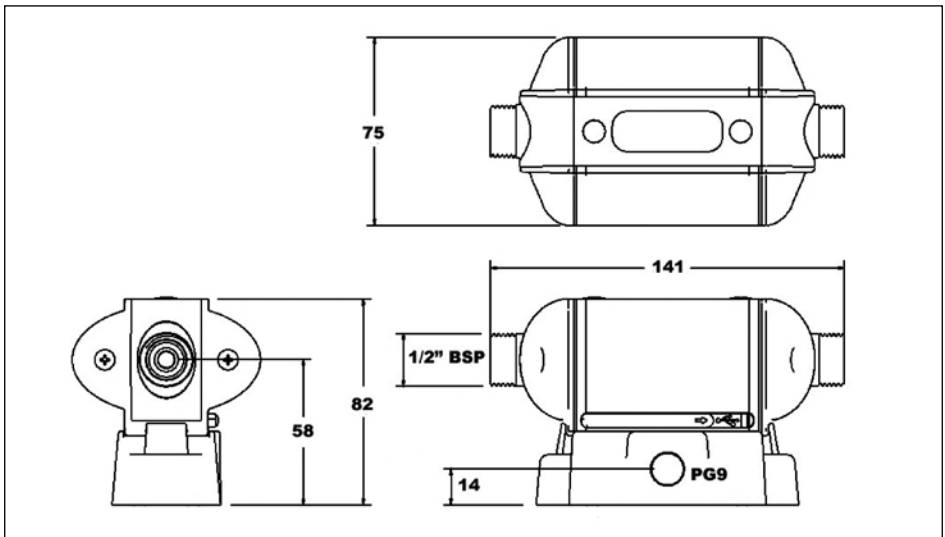

Mount the connection box, using suitable fixings, onto a rigid surface with the cable entry at the bottom. The mounting screw centres are shown in the diagram on the right. When the flowmeter is clipped in place have the terminal screws at the lower edge. Note the rubber strip covering the terminals on the meter will not seal if

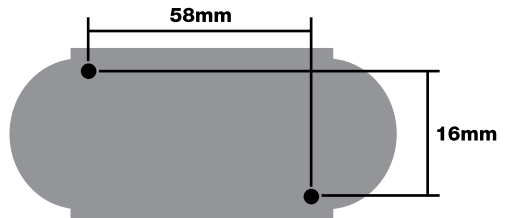

water is persistently present in this area. Ensure the meter is not pressure washed. The Atrato can easily be dismantled by inserting a screwdriver under the mounting clip and gently unclipping it to release the main body. The PG9 thread can be either connected to suitable flexible conduit or be fitted with the supplied cable gland.

3 Electrical

The Atrato can be used entirely from a computer using the USB connection but this may not be acceptable in many situations where remote operation or further functions are required. The unit will work with systems from Windows XP onwards. The maximum connector cable size is 2.5mm (22-14AWG), for ease of assembly we recommend 1mm maximum. Care should be taken when terminating the wires as the conductors should be stripped to 4 to 5mm maximum and the wire ends must be pushed fully into the connector before tightening. These cables pass through a slot cut in the aluminium housing please ensure that no bare conductors are clear of the surface of the connector strip prior to closing the housing.

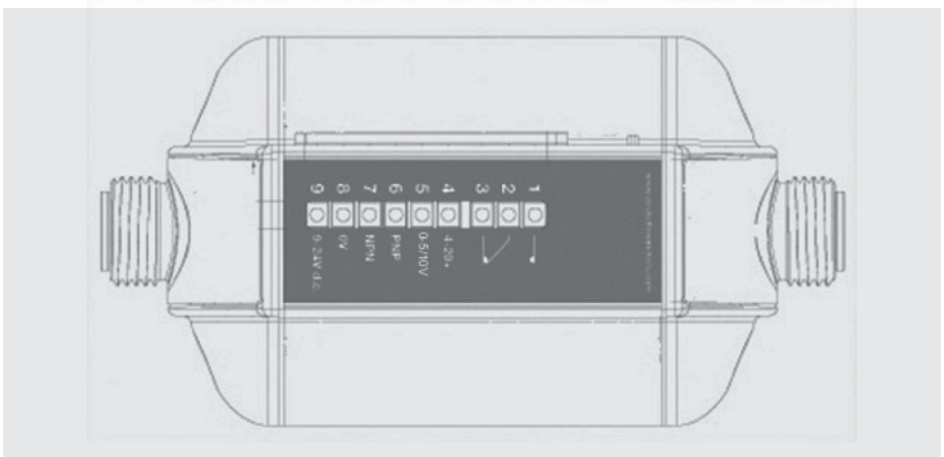

 = Operates on External Power OR USB

 = Operates on External Power only

Atrato Connector Assignments

Pin N°	Label	Function
1	RLY NO	Isolated relay contact; normally closed contact 24V 100mA
2	RLY CO	Isolated relay contact; change over contact 24V 100mA
3	RLY NC	Isolated relay contact; normally open contact 24V 100mA
4	4-20mA +	Analogue current (4~20mA) output (referenced to 0V)
5	0 – 5/10V	Analogue voltage (0~5/10V) output (referenced to 0V)
6	PNP	Output 1 open collector PNP OR Input 1 (5 – 24V dc) e.g. switch to pin 9
7	NPN	Output 2 open collector NPN OR Input 2 (5 – 24 V dc) e.g. switch to pin 9
8	0V	External ground; common for PNP, NPN and Analogue outputs
9	+9 -24 V dc	External power; 9V ~ 24V (> 12V for Analogue output)



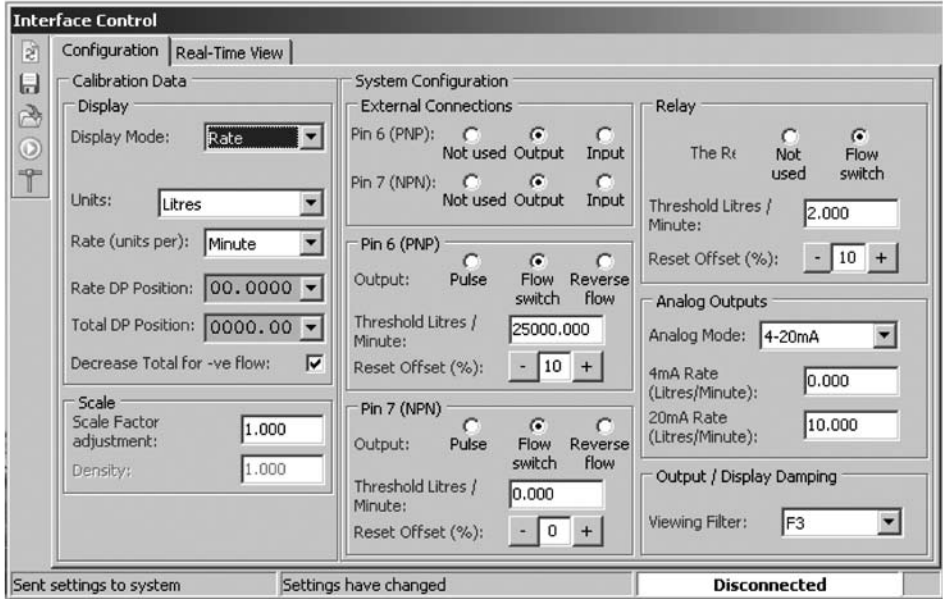

4 Setup

The Atrato low flow ultrasonic flowmeter should be setup using the USB interface and a suitable computer. Below is a screen shot of the interface configuration screen.



The 2 tabs at the top of the display are “configuration” and “real-time view”, figure 4, above, is the configuration display. Figure 5 below shows the function of the top left buttons.

Control buttons to apply the settings and recover previously set parameters

-  Refresh settings to the Atrato
-  Save settings to a file on the computer
-  Retrieve previously saved file
-  Operate flowmeter
-  Check analogue output

DISPLAY

DISPLAY MODE: This button cycles through the display options in the “real time view” as well as the LCD display if one is fitted. The options are:-

- RATE** – this is showing just flow rate
- TOTAL** – the display just shows total
- BOTH** – the display can be cycled from rate to total using the left hand button or a remote input if either pin 6 or pin 7 is selected for this.
- BATCH** – this is a separate function and several selection parameters change once this is chosen.

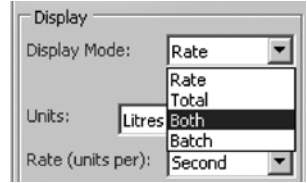

RIGHT PUSH BUTTON RESETS TOTAL: Check this box if you require the total resettable by either the right push button or remotely through pin 6 or 7.

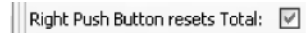

UNITS: A drop down menu offers the choice of - Litres, cc, gms, kg, US gallon, Imperial gallon or Custom units.

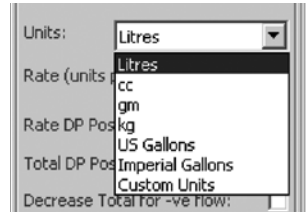

RATE (units per): This is the time base for the flow rate and has the option of Second, Minute or Hour.

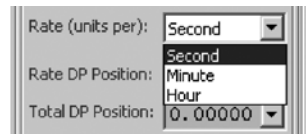

RATE DP POSITION: Use the drop down menu to choose the required decimal point position.

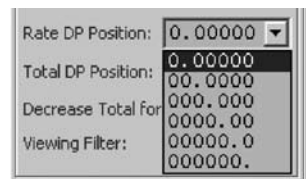

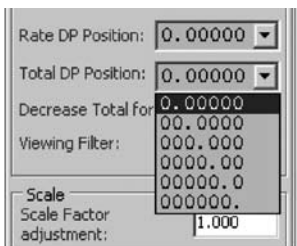

TOTAL DP POSITION: Use the drop down menu to choose the required decimal point position.

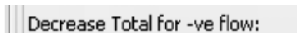

DECREASE TOTAL FOR -VE FLOW: Check this box if you require the displayed total to reduce with reverse flow.

SCALE

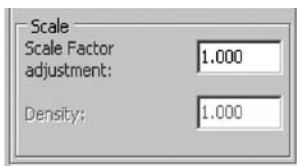

SCALE FACTOR ADJUSTMENT: This is a fine tune adjustment on the signal to compensate from errors introduced by erratic flow or other system irregularities.

DENSITY: The flowmeter is fundamentally a volumetric device but a density figure can be entered here if one of the mass units are selected. Caution must be used however as there is no temperature/density correction.

EXTERNAL CONNECTIONS

PIN 6 (NPN): Pin 6 can be configured as either outputs or inputs but not both simultaneously. If one input and one output is required the user must determine whether they require a NPN or PNP output and use the appropriate terminal for each action. The options are – Not used Output or input .

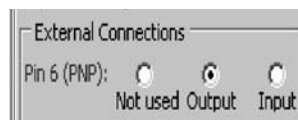

PIN 7 (PNP): Pin 7 can be configured as either outputs or inputs but not both simultaneously. If one input and one output is required the user must determine whether they require a NPN or PNP output and use the appropriate terminal for each action.



NOTE: the operation for Pin 6 and Pin 7 are identical with the exception of the type of transistor output. These instructions are the same for pin 7 except the Pin 6 (PNP) would read Pin 7(NPN).

PIN 6 (PNP)/PIN 7 (NPN)

The contents of this box will change depending on the selection made in the [External connection](#) box.

If **OUTPUT** is selected the check box options are:-

Pulse Flow switch Reverse flow

PULSE: Enter the number of pulses per unit volume required. This figure can be adjusted to suit the application and the flow range required from the meter. The maximum output frequency is 400 Hz. So care must be taken to ensure that this pulse rate is not exceeded.

E.g. 10 L/Min at 400 Hertz equals $(400 \times 60)/10 = 2400$

Therefore 2400 pulses per litre is the maximum resolution for 10 litres per minute assuming maximum frequency output. If the meter is being used up to 5 L/Min the pulse output and so resolution could be doubled to 4800 P/L.

FLOW SWITCH: The lower area of the section changes so that the user can enter the Threshold at which the transistor is to operate.

THE RESET OFFSET (%): (Hysteresis) is either negative or positive depending on whether a falling or rising alarm is required. This is to prevent output flutter if the flow is cycling around the set point value. To reduce power consumption the transistor is off if positive hysteresis is selected and only powers when the threshold is exceeded. If negative hysteresis is chosen the transistor is on up to the set point. The increments are preset and can be cycled through using the + &- buttons. If more than one set point is required either both transistors must be used or one transistor and the relay. The right hand push button (or pin 7 set as an input) temporarily cancels the relay and resets the system.

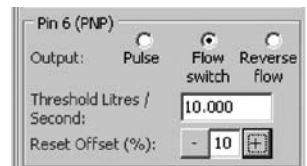
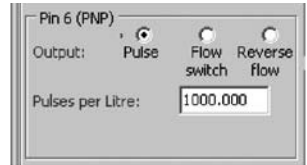

EXTERNAL CONNECTIONS

If **INPUT** is selected either the left or right push button function can be operated remotely by switching a suitable voltage (between 5 and 24V dc) to the pin with the common 0V line.

An external switch should be connected to +V for PIN 6 & 0V for PIN 7. PIN6 will require a 10K Ohm pull up resistor to the +V and PIN 7 would require a 10K Ohm pull down resistor to 0V.

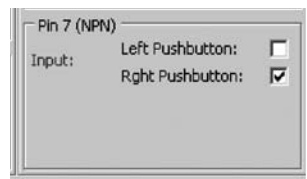

RELAY

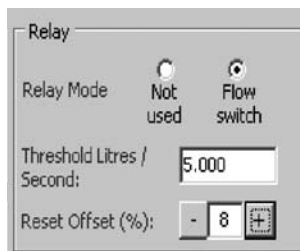

RELAY MODE: If the relay is required for a flow switch check the flow switch box and a further set of options for set point and hysteresis will appear.

THRESHOLD: Set the required flow rate for the flow switch. The **Reset Offset (%)** (Hysteresis) is either negative or positive depending on whether a falling or rising alarm is required. The relay has change over contacts but to reduce power consumption the relay is off if positive hysteresis is selected and only powers when the threshold is exceeded. If negative hysteresis is chosen the relay is on up to the set point. The increments are preset and can be cycled through using the + &- buttons. If more than one set point is required either both transistors must be used or one transistor and the relay.

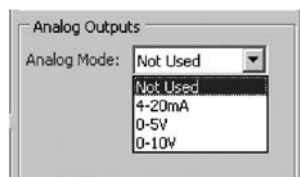

ANALOGUE OUTPUTS

ANALOGUE MODE: There are four options on the drop down menu: Not Used, 4-20mA, 0-5 Volt and 0-10 Volt. Once the selection has been made a further two boxes for entry of the analogue output at zero flow and full scale appear. These are numeric entries in the units and time base selected earlier.

OUTPUT/DISPLAY DAMPING

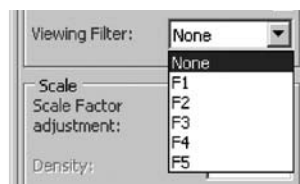

VIEWING FILTER: This prevents the display, flow switches and analogue outputs from jittering with irregularities in the flow from say a peristaltic pump. The increments are arbitrary with the degree of damping approximately doubling with each level. F5 will take perhaps a minute to stabilise.

CALIBRATION FREQUENCY

Checking this box gives a full scale output analogue voltage or current to check the system wiring and ancillary equipment. To turn off this temporary output simply uncheck the box. No other changes can be made with this box open.

REAL TIME VIEW: The large display reflects the meter readings showing on the LCD display if fitted and will mimic that display. The buttons either side have the functions selected in the System Configuration Settings and also work in parallel with the buttons on the flowmeter LCD unit. The small window below the rate and total display shows various relevant operational parameters whilst the unit is operating e.g. relay status and frequency output if these options are selected or in batch mode overflow or under fill.

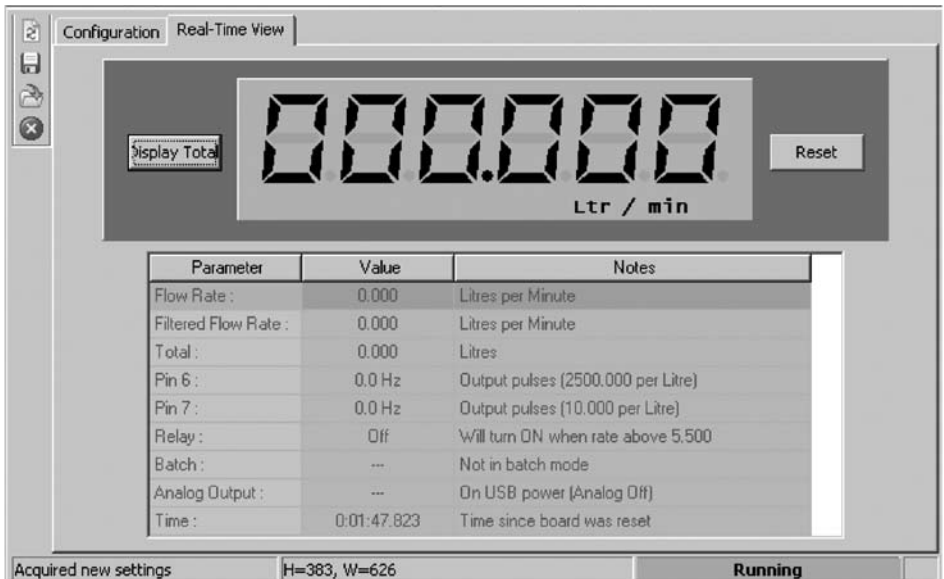

FLOW RATE:

This is the instantaneous flow rate and is updated approximately every 100 milliseconds.

FILTERED FLOW RATE:

This is the filtered flow rate and is identical to the LCD display on the flowmeter (if fitted) and the speed of change will depend on the filter setting. The filter will also affect the response time for the analogue outputs and the flow switches.

TOTAL:

The total liquid passed since the last reset.

PIN 6 & 7:

If no selection is made “Not used” will be in the Notes column. See following text and chart for the display legends.

OR:- When Pin 6 or 7 is set to “Output” and set to “Pulse” this will display the frequency of the running output and the number of pulses per litre selected.

OR:- If it is selected to “Output” and set to “Flow switch” the Value column will show the transistor status either “low” or “high” and the notes will show the selected switch points.

OR:- If “Output” and “Reverse Flow” are selected the Value column will show either “low” or “high” depending on forward or reverse flow.

OR:- If “Input” is selected the Value column will show “high” or “low” depending on the switch condition and “Input Logic level” in the Notes column.

The chart below shows the message details for a variety of configuration settings and meter running conditions.

		External connections Pin 6 or 7 real time viewer Values and notes					
		Configuration settings					
		Not used	Output			Input	
			Pulse	Flow Switch	Reverse Flow	Left push button	Right push button
Parameter	Value options	Notes					
Pin 6 or Pin 7	Off	Pin 6 & 7 not being used					
	0.00 Hz		Output pulses (Pulses per unit volume)				
	Off				Will turn On when rate above (entered value).		
	On				Will turn Off when rate below (entered value).		
	Forward				Direction of flow		
	Reverse				Direction of flow		
	Low					Input logic level	
	High					Input logic level	
	Low						Input logic level
	High						Input logic level

PIN 7: The display for “Pin 7” will function the same as “Pin 6” (see above).

RELAY: If no function is set for the relay the Value column will show “Off” otherwise it will display the function and its operating parameters.

BATCHING OPTION: If Batch is selected in the “Display mode” the relay is automatically assigned to the total display for batching pre-set volumes of liquid. The preset batch size can be entered in the relay box. This value will be seen on the LCD display and will count down when the left hand start button is pressed. The batch can be interrupted by pressing the right hand start button, in the paused state a further press of the right button cancels the batch. If you wish to continue the batch from the paused state the left hand button continues the dispense from the point it was interrupted.

If an alternative batch size is required after the unit is disconnected from the computer pressing both buttons together for 3 seconds will permit the batch size to be altered by using the right hand key to increment the digit that is flashing and the left hand button to advance to the next digit. Holding the left button for 3 seconds enters the selected numbers and the meter is ready to begin batching. Both buttons can be operated remotely if required e.g. for remote start/stop signals.

TECHNICAL SPECIFICATION

Linearity	±1.5% of reading over flow range
Repeatability	±0.1% from 25% to 100% ±0.5% from 0 -25%
Housing	IP54
Temperature range	-10 to 60°C non condensing
Fluid temperature range	-10 to 60°C (110°C model in development)
Storage temperature	-20 to 100°C
Pulse output	PNP or NPN maximum frequency 400 Hz
Relay	24 Vdc 500 mA max non inductive
PIN 6 Transistor O/P	PNP 24 V @ 20 mA max
Input	Pull down resistor required (10K Ohm)
PIN 7 Transistor O/P	NPN 24 V @ 20mA maximum
Input	Pull up resistor required (10K Ohm)
LCD display	Reflective 6 X 8mm high main characters 2.5mm enunciators Gal. cc. Kg. gms. Ltr. /min /Hr /Sec
4 – 20 MA output	into 250 Ohm maximum 14 Bit resolution ±0.1% linearity (plus flowmeter accuracy)
0 – 10 Volt output	14 Bit resolution (14 V dc min supply voltage) ±0.1% linearity (plus flowmeter accuracy)
0 – 5 Volt output	12 Bit resolution
USB	Type A connector Windows XP or later
Wiring Terminals	1mm maximum
Power supply	10 – 24 V dc (15 -24V dc for 4-20mA or 0-10V)
Power consumption	110 mA (plus analogue output current)
Connections	1/2" BSP male Alternative - 3/8" John Guest push in

MATERIALS OF CONSTRUCTION

End fittings	PEEK, Food & Medical grade
Flow tube	316 Stainless steel as standard Alternative - Borosilicate glass
Seals	Viton as standard Alternative – Nitrile, EPDM, Silicon
Housing	Aluminium extrusion
End caps	ABS
Mounting bracket	ABS
External elastomeric seals	PTE



JLC International
Phone: 215-340-2650
Fax: 215-340-3670

948 Lenape Drive Town Center, New Britain, PA 18901
jlcusa@jlcinternational.com
www.jlcinternational.com